

# FALC

## mod. HD

### FRESATRICE - FRAISE - ROTARY TILLER FRÄSE - FRESADORA

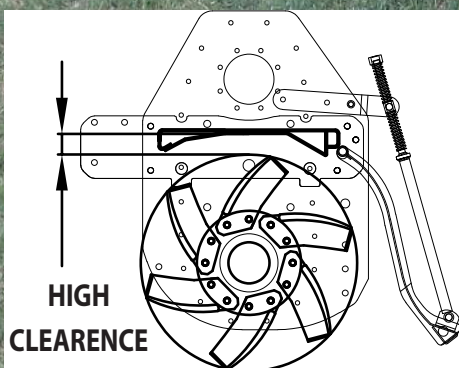

**Fresatrice per la preparazione del letto di semina in terreni medio-pesanti.  
Per trattori da 60 a 100 HP**



**Fraise pour la preparation du lit de semence en terrains moyen-lourds.  
Pour tracteurs de 60 à 100 CV**



**Rotary tiller for the preparation of the seedbed in medium-heavy soils.  
For 60-100 HP tractors**



**Fräse für die Saatbettvorbereitung in mittelschweren Böden.  
Für Traktoren von 60 bis 100 PS**



**Fresadora para la preparación del lecho de siembra en suelos medio-pesados.  
Para tractores de 60 a 100 CV**



# mod. HD



60-100 HP

# FALC

HD									"ROTKING" 	
	A mm.	B mm.	A inches	B inches	KG	LBS	N.	N.		
1600	1576	1743	62,04	68,62	560	1234	36	26		
1800	1821	1988	71,69	78,26	615	1355	42	30		
2100	2066	2233	81,33	87,91	660	1455	48	34		
2300	2311	2478	90,98	97,55	710	1565	54	38		
2500	2556	2723	100,63	107,20	750	1653	60	42		
2800	2801	2968	110,27	116,85	790	1741	66	46		



- Rotore a 6 zappe elicoidali per disco
- Ammortizzatori a molle nel cofano posteriore
- Slitte
- **Opzioni:** tenute stagne, controflange, slitte usura in Hardox



- Rotor avec 6 houes par disque
- Ammortisseurs à ressorts sur capot arrière
- Patins
- **Options:** étanchéité d'huile, contrebrides, patins d'usure en Hardox



- Rotor with 6 helical hoes each disc
- Spring shock absorbers for rear bonnet
- Skids
- **Options:** watertights, double flanges, Hardox wear & tear skids



- Rotor mit 6 Spiralhacken jeder Scheibe
- Feder-Stoßdämpfer für die hintere Haube
- Kufen
- **Optionen:** wasserdichte Dichtungen, Gegenflansche, Verschleißkufen aus Hardox



- Rotor con 6 azadas helicoidales por disco
- Amortiguadores de muelles en el capó trasero
- Patines
- **Opciones:** sellos estancos, contrabridas, patines de desgaste de Hardox

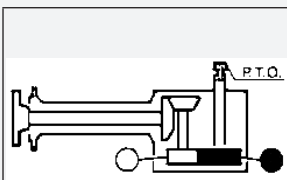

IN DOTAZIONE  
EN DOTATION  
ON ISSUE  
AUSRÜSTUNG  
EN DOTACIÓN

- \* VELOCITÀ INSERITA
- \* VITESSE BRANCHEE
- \* PLUGGED SPEED
- \* EINGELEGTER GANG
- \* VELOCIDAD PREDISPUESTA

● 18	● 19	● 21	● 23
○ 23	○ 21	○ 19	○ 18
156	180*	220	255
289	334	/	/

540  
 1000



## OPZIONI OPTIONS OPTIONS OPTIONEN OPCIONES



**Coppia dischi anteriori d=360**



**Couple de disques frontaux d=360**



**Pair of front discs d=360**



**Paar vordere Scheiben D=360**



**Par de discos anteriores d=360**



**Ripuntatore rompitraccia frontale**

**Efface-trace frontal**

**Front trace breaker**

**Vordere Spurlockererzinke**

**Borrahuella frontal**



**Coppia ruote 4.00-10/4**

**Couple roues 4.00-10/4**

**Pair of wheels 4.00-10/4**

**Räderpaar 4.00-10/4**

**Par de ruedas 4.00-10/4**



# FALC

Via Proventa, 41  
48018 Faenza (Italia)  
Tel. +39 0546 29050

[www.falc.eu](http://www.falc.eu) | [info@falc.eu](mailto:info@falc.eu)

