

FALC

mod. WIND

**TRINCIASTOCCHI - BROYEUR - SHREDDER
HÄCKSLER - TRITURADORA**



Trinciatrice robusta e professionale per stocchi, paglia, cotone, pascolo e *cover crops*. Per trattori da 70 a 180 HP

Broyeur robuste et professionnel pour tiges de maïs, paille, coton, pâturage et couvert végétal. Pour tracteurs de 70 à 180 CV

Robust and professional shredder for cornstalks, straw, cotton, meadows and cover crops. For 70-180 HP tractors

Profi und starker Häcksler für Maisstängel, Stroh, Baumwolle, Weide und *cover crops*. Für Traktoren von 70 bis 180 PS

Trituradora robusta y profesional para tallos de maíz, paja, algodón, pastos y *cover crops*. Para tractores de 70 a 180 CV





WIND										
	kg	lbs	A mm.	B mm.	A inches	B inches	N.	HP	PTO	N.
2700	1326	2923	2665	2960	104,92	116,54	56	70-180	1000	6
3200	1441	3177	3184	3479	125,35	136,97	68	70-180	1000	6
3200 DT	1681	3706	3184	3498	125,35	137,72	68	70-180	1000	4+4
4000	1671	3684	4015	4310	158,07	169,69	88	70-180	1000	6

ATTACCO POSTERIORE

ATTELAGE ARRIERE

REAR HITCH

HECKANBAU

ENGANCHE TRASERO



1. Coltello "Y" (tipo 01) e controcoltello liscio
2. Tendicinghie automatico (foto 1)
3. WIND 3200 DT: doppia trasmissione
4. Lamiera d'usura (a richiesta)
5. Controcoltello dentato (a richiesta)
6. A SCELTA: con rullo posteriore, con ruote posteriori, con slitte.



1. Couteau "Y" (type 01) et contre couteau lisse
2. Tendeur automatique des courroies (photo 1)
3. WIND 3200 DT: double transmission
4. Tôle d'usure (sur demande)
5. Contre couteau cranté (sur demande)
6. A CHOIX: avec rouleau arrière, avec roues arrière, avec patins.



1. "Y" blade (type 01) and smooth counter blade
2. Automatic belt tightener (photo 1)
3. WIND 3200 DT: double drive
4. Wear & tear sheet (on request)
5. Toothed counter blade (on request)
6. ON CHOICE: with rear roller, with rear wheels, with skids.



1. Messer „Y“ (Typ 01) und glattes Gegenmesser
2. Automatischer Riemenspanner (Foto 1)
3. WIND 3200 DT: Doppelantrieb
4. Verschleißblech (auf Wunsch)
5. Gezahntes Gegenmesser (auf Wunsch)
6. NACH WAHL: mit hinterer Walze, mit hinteren Rädern, mit Kufen.



1. Cuchilla "Y" (tipo 1) y contracuchilla lisa
2. Tensor automático de las correas (foto 1)
3. WIND 3200 DT: doble transmisión
4. Chapa de desgaste (a pedido)
5. Contracuchilla dentada (a pedido)
6. A ELECCION: con rodillo trasero, con ruedas traseras, con patines.

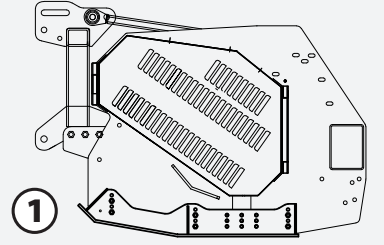
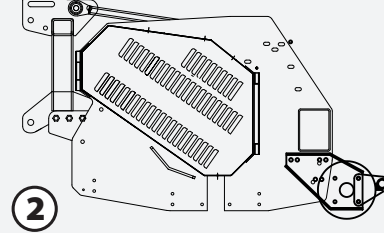
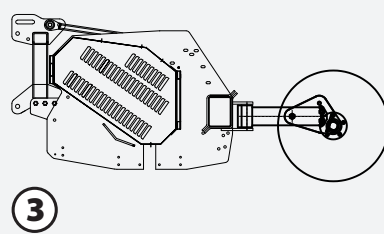

 <p>1</p>	<ul style="list-style-type: none"> 1. Macchina con slitte regolabili 1. Machine avec patins réglables 1. Machine with adjustable skids 1. Maschine mit verstellbaren Kufen 1. Máquina con patines regulables
 <p>2</p>	<ul style="list-style-type: none"> 2. Macchina con rullo 2. Machine avec rouleau 2. Machine with roller 2. Maschine mit Walze 2. Máquina con rodillo
 <p>3</p>	<ul style="list-style-type: none"> 3. Macchina con coppia ruote sterzanti 3. Machine avec couple de roues braquantes 3. Machine with pair of steering wheels 3. Maschine mit Paar Stützrädern 3. Máquina con par de ruedas terciantes

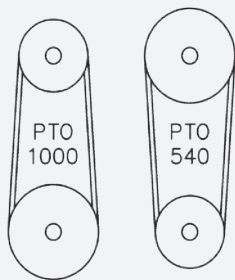

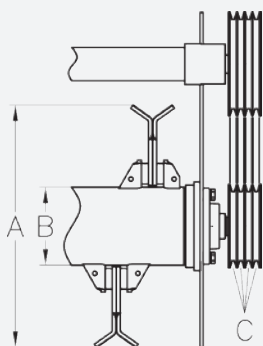

- Invertendo la posizione delle pulegge si passa da PTO 1000 a PTO 540**
- Inversant la position des poulies on passe de PDF 1000 à PDF 540**
- Inverting the position of the pulleys you change from PTO 1000 to PTO 540**
- Um die Umdrehungen von 1000 bis 540 zu wechseln, muss man die Riemenscheiben vertauschen**
- Invertiendo la posición de las poleas, se pasa de TDF 1000 a TDF 540**

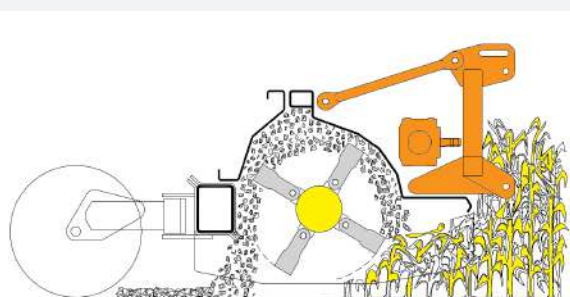

2700-3200 3200 DT-4000	A	Ø mm 663
2700-3200 3200 DT-4000	B	Ø mm 244,5x10
3200DT:	C	n. 4+4
2700-3200-4000:		n. 6

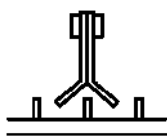
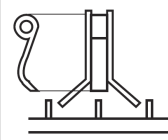
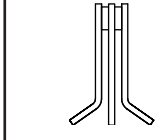
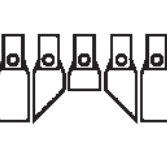
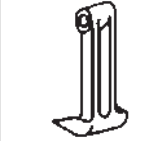

	Velocità periferica dei coltelli
	Vitesse périphérique des couteaux
	Blade tip speed
	Umfangsgeschwindigkeit der Messer
	Velocidad periferica de las cuchillas
WIND	m/s inches/s
2700-3200-3200 DT	72 2835
4000	61 2402

OPTION		
 ①	 ①V	 ①C
 ③	 ④	 ⑨

	G/M del rotore
	T/min du rotor
	Rotor RPM
	Rotor U/min
	RPM del rotor
WIND	n.
2700-3200-3200 DT	2058
4000	1744

mod. WIND



70-180 HP

FALC

OPZIONI **OPTIONS** **OPTIONS** **OPTIONEN** **OPCIONES**



3

- Perni filettati con dado
- Axes filètes avec écrou
- Threaded axles with nut
- Gewindebolzen mit Mutter
- Pernos roscados con tuerca



4

- Slitte fisse / regolabili
- Patins fixes / réglables
- Fixed/adjustable skids
- Feste/verstellbare Kufen
- Patines fijos/regulables

- Catene (al posto delle bandelle anteriori)
- Chaînes (au lieu des feuillards frontaux)
- Chains (instead of front flaps)
- Ketten (anstelle der vorderen Beschlägen)
- Cadenas (en lugar de las chapas de protección delanteras)



5



6

- Coppia ruote sterzanti
- Couple de roues braquantes
- Pair of steering wheels
- Paar Stützräder
- Par de ruedas terciantes

2700-3200-3200DT: 195/70 R15 / 5
4000: 10.00/75-15.3/ 5

- Carrello di trasporto per mod. 4000
- Chariot de transport pour mod. 4000
- End tow kit for mod. 4000
- Fahrgestell für Mod. 4000
- Carro de transporte para mod. 4000



7



8

- Rullo posteriore: 273x6
- Rouleau arrière: tube 273x6
- Rear roller: tube 273x6
- Hintere Walze: Rohr 273x6
- Rodillo trasero: tubo 273x6



FALC

Via Proventa, 41
48018 Faenza (Italia)
Tel. +39 0546 29050

www.falc.eu | info@falc.eu





FALC

mod. WIND 4800 DT/2R
mod. WIND 6000 DT/2R

TRINCIASTOCCHI - BROYEUR - SHREDDER
HÄCKSLER - TRITURADORA



Trinciatrice per stocchi, paglia, pascolo e cover crops.
Per trattori da 100 a 200 HP



Broyeur pour tiges de maïs, paille, pâturage et couvert.
Pour tracteurs de 100 à 200 CV



Shredder for cornstalks, straw, meadows and cover crops.
For 100-200 HP tractors



Häcksler für Maisstängel, Stroh, Weide und cover crops.
Für Traktoren von 100 bis 200 PS



Trituradora para tallos de maíz, paja, pastos y cover crops.
Para tractores de 100 a 200 HP



mod. WIND 4800 DT/2R
mod. WIND 6000 DT/2R



100-200 HP

FALC

WIND									
	kg	lbs	A mm	B mm	A inches	B inches	N.	HP	PTO
WIND 4800 DT/2R	2600	5732	4821	5231	189,80	205,94	104	100-200	1000
WIND 6000 DT/2R	3150	6945	6081	6491	239,41	255,55	136	100-200	1000

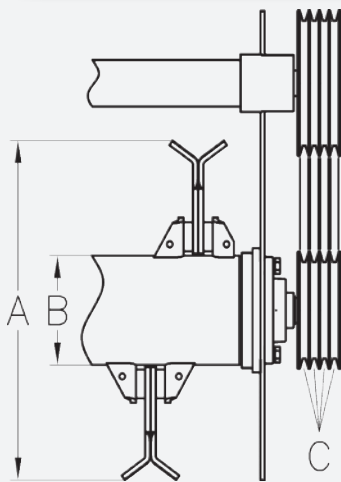

WIND 4800 DT WIND 6000 DT	A	Ø mm. 663
	B	Ø mm. 244,5x10
	C	n.5+5

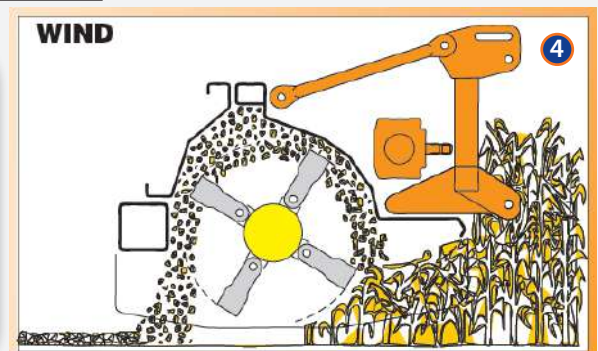

Velocità periferica dei coltelli	71 m/sec
Vitesse périphérique des couteaux	
Blade tip speed	
Umfangsgeschwindigkeit der Messer	
Velocidad periférica de las cuchillas	

G/M del rotore	2030
T/min du rotor	
Rotor RPM	
Rotor U/min	
RPM del rotor	

OPZIONI **OPTIONS** **OPTIONS**
OPTIONEN **OPCIONES**

①	④	④



FALC

Via Proventa, 41
48018 Faenza (Italia)
Tel. +39 0546 29050
Fax +39 0546 663986

